

Series 757

757 Double Check Valve Assemblies

757 DCDA Double Check Detector Assemblies



Superior Backflow Protection from Watts

When it comes to protecting the health and safety of people, why choose anything but the best? Series 757 SilverEagle® backflow prevention assemblies incorporate the latest design features to protect against contamination

at non-health hazard cross-connections. The SilverEagle series is the most compact and the lightest, offering the most flexibility of any backflow assembly in the industry. Specify the valve with safety at its core!

Features

- Closest competitor is more than 360% heavier
- Most compact design in the industry
- Entire valve body and closure sleeve manufactured from 300 Series stainless steel
- Approved with gate valves or UL Classified and FM Approved butterfly valves
- Approved for horizontal, N-pattern, and Z-pattern installations
- Uses groove connections for ease of installation and pipe alignment
- Patented Tri-Link check module allows ease of serviceability
- Smallest enclosure footprint
- Replaceable check disc rubber
- Available with quarter-turn ball valve shutoffs (2½" to 3")



Assembly Characteristics

Lay Length

Compare 4" Double Check with Shutoff Valves

Backflow Assembly	Laylength (in.)	Longer Than Watts
Watts 757	31.9	
FEBCO 850 W/OS&Y - GPC 5/01	46.2	58%
Wilkins 350 W/OS&Y - BF 350	37.7	29%

Typical Fire Flow Rates – 15 FPS

2½"	224 gpm	6"	1350 gpm
3"	350 gpm	8"	2400 gpm
4"	500 gpm	10"	3700 gpm

Assembly Weight

Compare 4" Double Check with Shutoff Valves

Backflow Assembly	Weight (lb)	Heavier Than Watts
Watts 757	61	
FEBCO 850 W/OS&Y - GPC 5/01	312	411%
Wilkins 350 W/OS&Y - BF 350	281	360%

Referenced Flow Characteristics (Horizontal)

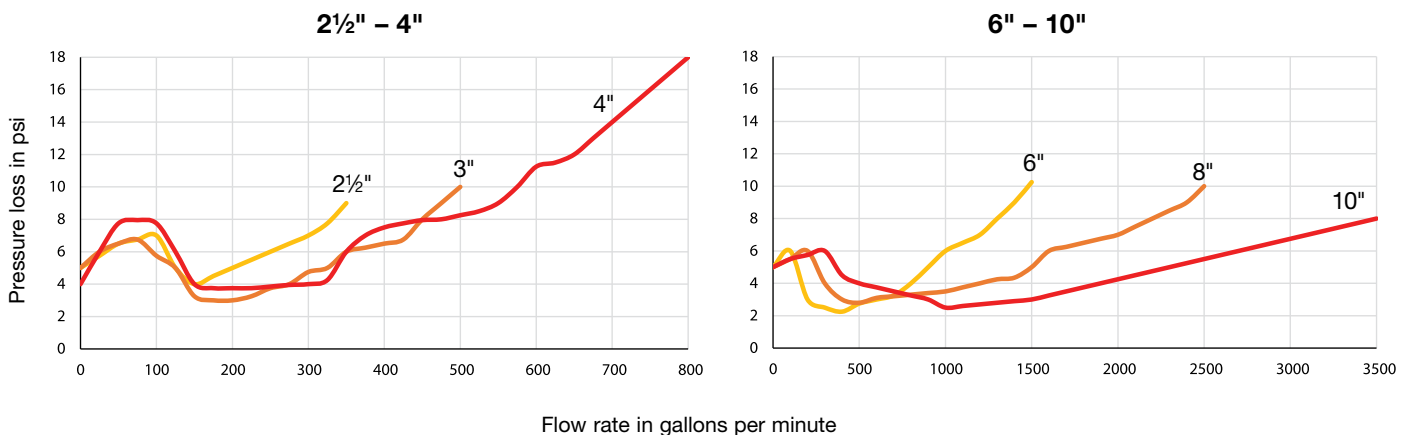

Dimensions and Weight

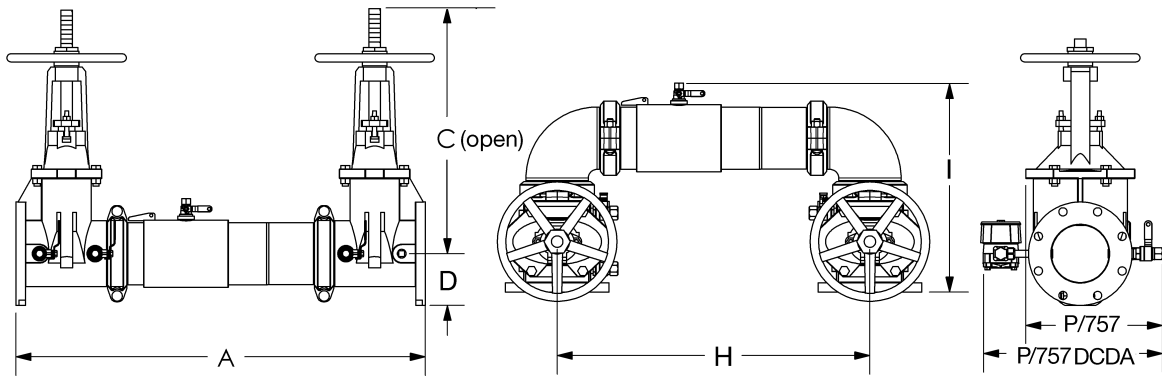

With OSY Gate Valves

With Butterfly Valves*

Size	A	C	D	H	I	P		Weight** (lb)		A	C	D	H	I	P		Weight** (lb)	
						DC	DCDA	DC	DCDA						DC	DCDA	DC	DCDA
2½"	31"	16⅞"	3½"	22"	15½"	9⅞"	13⅜"	125	139	28"	8"	3½"	22"	14⅝"	9"	13"	56	70
3"	31⅛"	18⅞"	3⅛"	22¾"	17⅞"	10½"	14½"	145	159	28½"	8⅞"	3⅛"	22¾"	15⅞"	9½"	13½"	54	68
4"	33⅛"	22¾"	4"	24"	18½"	11⅞"	15⅜"	161	175	29⅞"	8⅝"	3⅛"	24"	16¼"	10"	14"	61	75
6"	43½"	30⅞"	5½"	33¾"	23⅞"	15"	19"	295	309	36½"	10"	5"	33¾"	19⅞"	10½"	14½"	117	131
8"	50"	37¾"	6⅛"	40⅝"	27⅞"	17⅞"	21⅜"	480	494	43"	12¼"	6½"	40⅝"	23⅞"	14⅞"	18⅜"	261	275
10"	57½"	45¾"	8⅞"	50"	32½"	20"	24"	781	795									

*UL Classified and FM Approved.

**For N-pattern weights, download ES-757/757N.

Available with Butterfly Valves or Quarter-Turn Ball Valves



Advantages of UL Classified and FM Approved Butterfly Valves

- Butterfly valves have built-in tamper switch wiring
- Backflow assembly is lighter and more compact
- Groove couplings ease installation and pipe alignment
- All butterfly valves display flow indicator flag

Advantages of Quarter-Turn Ball Valves

- Positive drip tight closure
- Fast quarter-turn operation
- Available in sizes 2½" to 3"
- Available for N-pattern horizontal installations
- Low operating torque



Cutaway View – Full Flow Operation

Normal Operation

In normal flowing operation, the independent torsion spring check remains closed until there is a water demand. Each check then opens and maintains an approximate 1 psi differential in the direction of flow. In a nonflow or backflow condition, both checks close until the resumption of normal flow.

Applications

Series 757. Double Check Valve assemblies are used to prevent backflow of pollutants that are objectionable but not toxic. Double Check Valve assemblies may be installed under continuous pressure service and may be subject to backpressure. The assemblies may be used in fire protection systems without chemical additives, industrial in-plant plumbing systems, and other systems requiring non-health hazard protection. Local codes may vary. Consult authorities for specific approved applications.

Series 757DCDA. Double Check Detector assemblies are used to prevent backflow of pollutants that are objectionable but not toxic. Double Check Detector assemblies may be installed under continuous pressure service and may be subject to backpressure. This series is used primarily on fireline sprinkler systems when monitoring unauthorized use of water is necessary.

Approvals

Refer to specification ES-757/757N.

Specification

The Double Check Valve assembly shall consist of two independent torsion spring check modules within a single housing with sleeve access, required test cocks, and drip tight shutoff valves. Torsion spring checks may be removed and reinstalled in housing without any special tools. The housing shall be constructed of 300 Series stainless steel with groove end connections. Torsion spring checks shall have reversible elastomer discs and in operation shall produce drip tight closure against reverse flow caused by backpressure or backsiphonage.

Assembly shall be a Watts 757 or 757DCDA.

Patent # 6,443,181 and 6,478,047

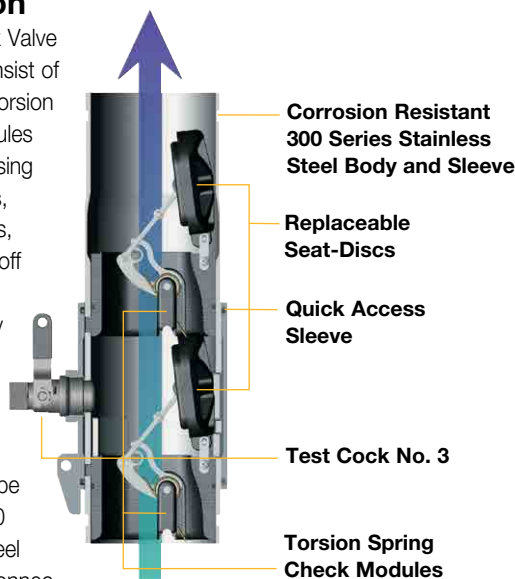

Installation Guidelines

Most field problems occur because dirt or debris present in the system at the time of installation becomes trapped in the first check seating area resulting in a low or zero differential across the first check. **Flush the system before the backflow valve is installed.** If the system is not flushed until after the backflow assembly is installed, remove both check modules from the valve and open the inlet shutoff to allow water to flow for a sufficient time to flush debris from the water line. If debris in the water system continues to cause fouling, install a strainer upstream of the backflow assembly.

Series 757 and 757DCDA can be configured for horizontal, N-pattern, and Z-pattern installation as long as implementation aligns with the direction of the flow arrow on the assembly and the local water authority approves the installation.

Install the assembly with adequate clearance around the valve to allow for inspection, testing, and servicing. Ensure there is a 12" minimum clearance between the lower portion of the assembly and the floor or grade.

Interior Installation

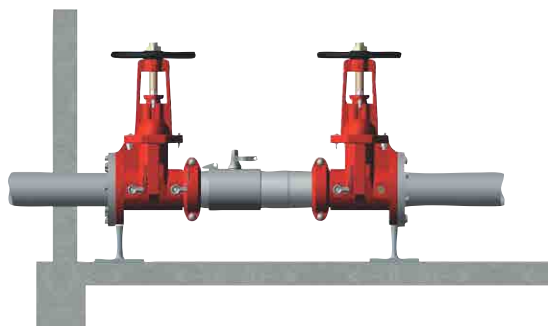

Enclosure Installation

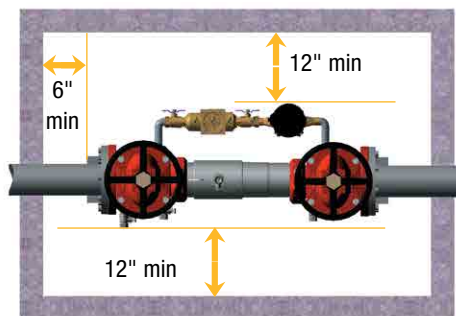

Characteristics and Materials

Rated Working Pressure	Hydrostatic Test Pressure
175 psi	350 psi
Temperature Range	Body Construction
33°F – 110°F	300 Series stainless steel

End Connection

Groove per AWWA C-606 (IPS) or Flange per ANSI B16.1, Class 125

2½" – 3" available with threaded QT ball valve shutoffs (Series 757)

